

## AWM 460 Arm Heavy Duty

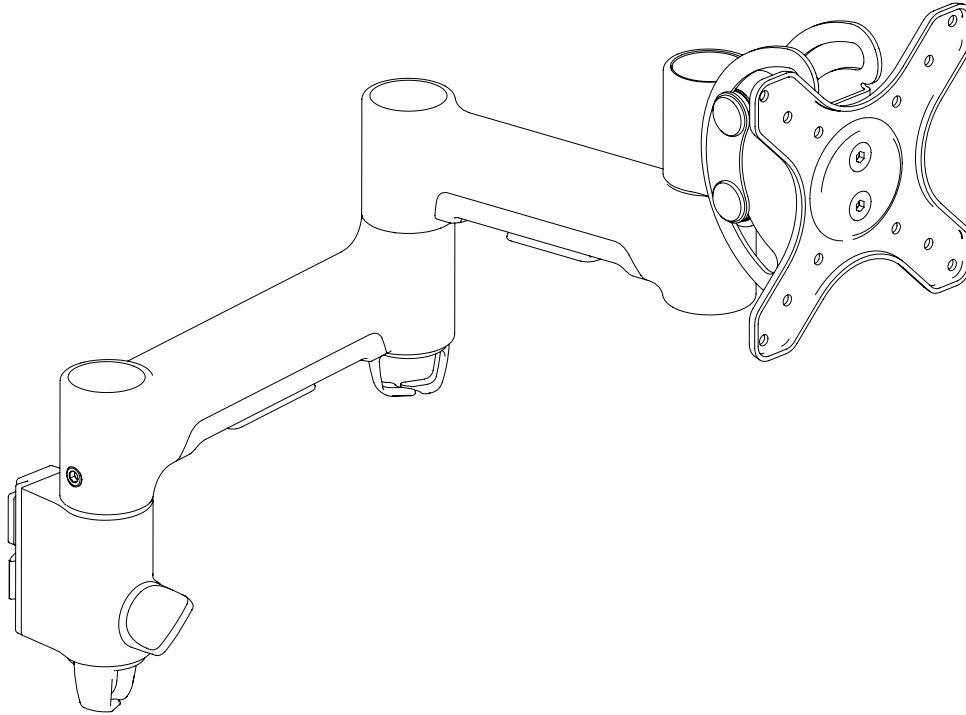

### COMPONENT CHECKLIST

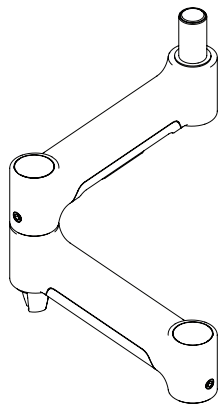

**A**  
Monitor Arm  
(x1)

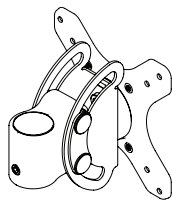

**B**  
Heavy Duty Tilt Head  
(x1)



**D**  
Screw  
M4x25mm  
(x4)



**E**  
Screw  
M4x16mm  
(x4)



**F**  
Screw  
M4x12mm  
(x4)

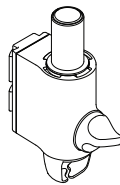

**C**  
Channel Clamp  
(x1)



**G**  
Spacer  
(x4)



**H**  
Security  
screw  
(x4)

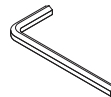

**I**  
4mm  
hex key  
(x1)

### REQUIRED TOOLS

- Phillips Head Screwdriver

### WEIGHT RANGE

#### Flat Monitors

0 - 14kg  
(0 - 31lbs)

#### Curved Monitors

0 - 12kg  
(0 - 26.5lbs)

Monitor weight should be within the weight range of all modular elements that make up the complete monitor mounting solution.

### IMPORTANT INFORMATION

- ! Please ensure this product is installed as per these installation instructions.
- ! Do not remove or throw away the plastic cap on the channel clamp.
- ! The manufacturer accepts no responsibility for incorrect installation.
- ! This product is compatible with Atdec AWM Series products.
- ! Curved monitors, deep devices (such as all-in-one PCs), VESA mounted accessories (such as mini PC brackets and mounts), and offset VESA locations exert additional leverage that can exceed the capacity of the mount even though the monitor weight may be within the stated range. Please contact Atdec if you would like further information.

## 1. Fix clamp to Post

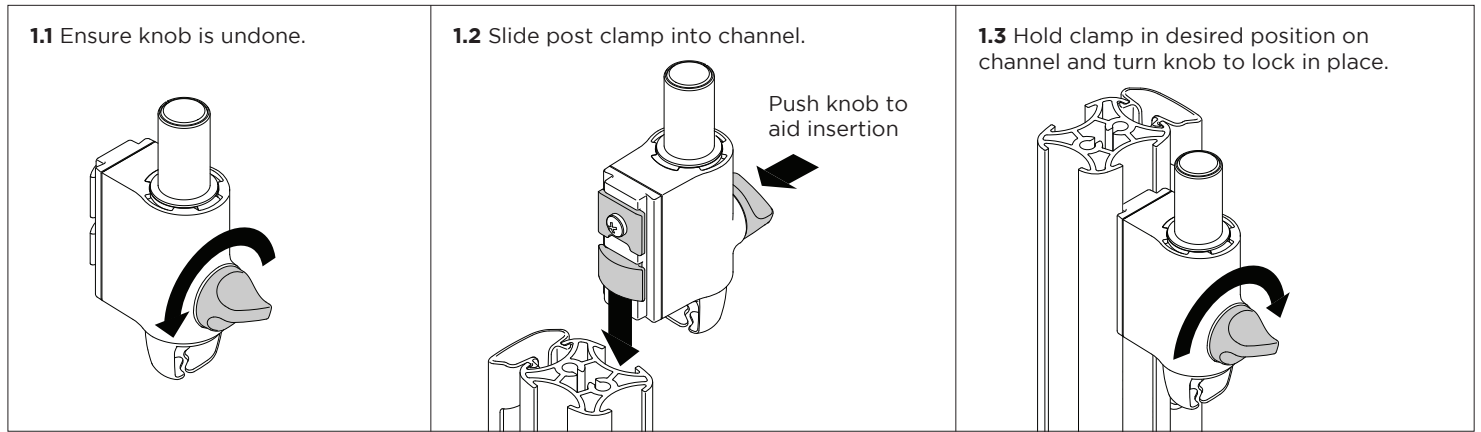

## 2. Set arm rotation to 180° (optional)

Note rotation is set to 360 by default.

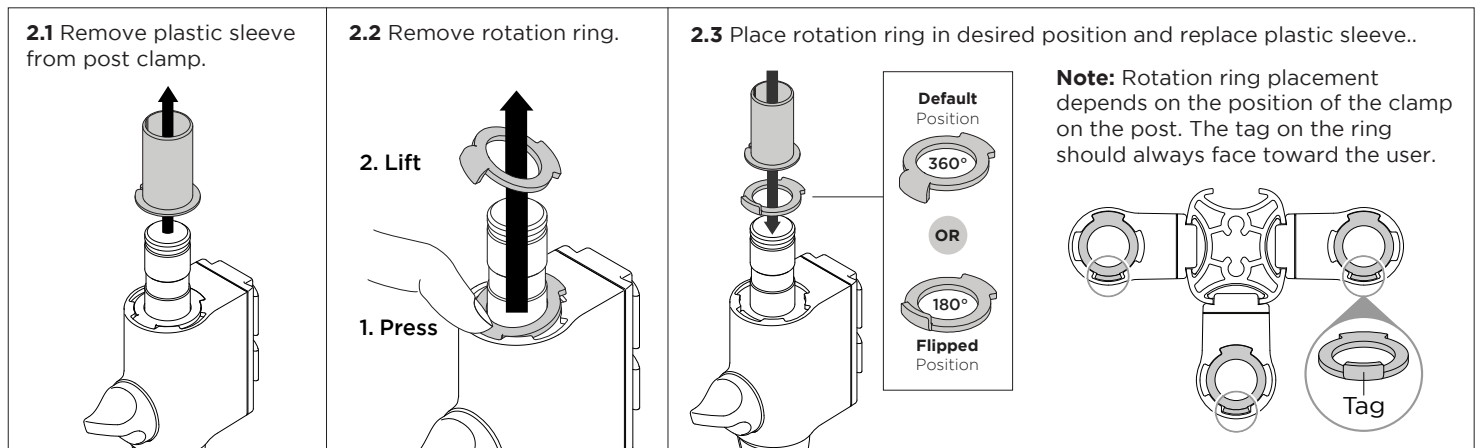

## 3. Fit arm to Channel Clamp

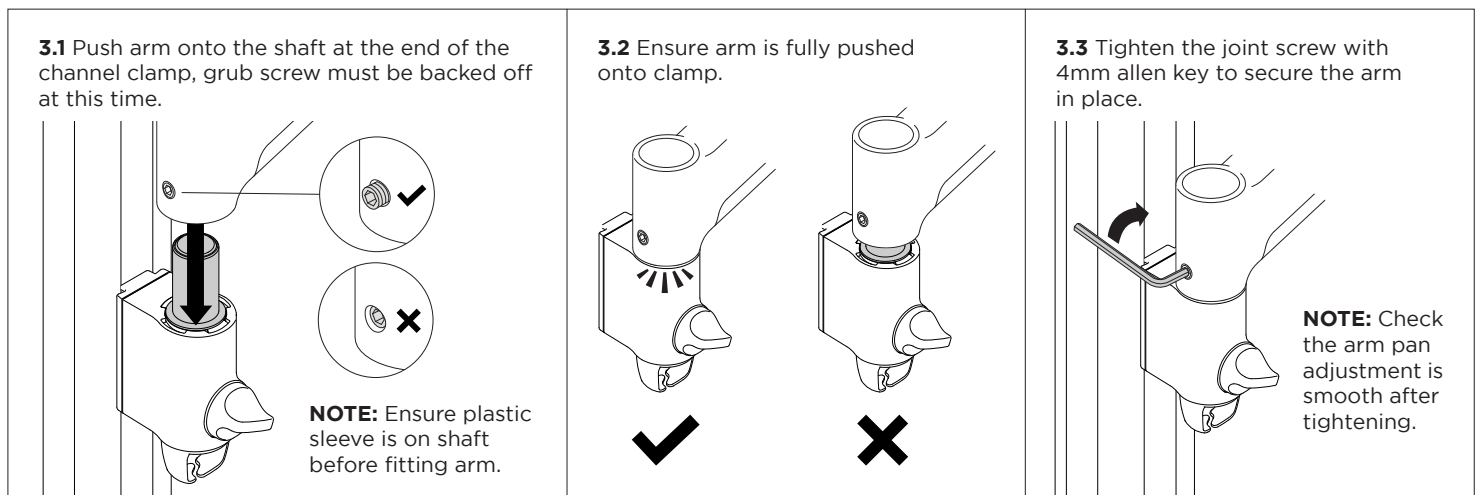

## 4. Adjust rotation tension (Optional)

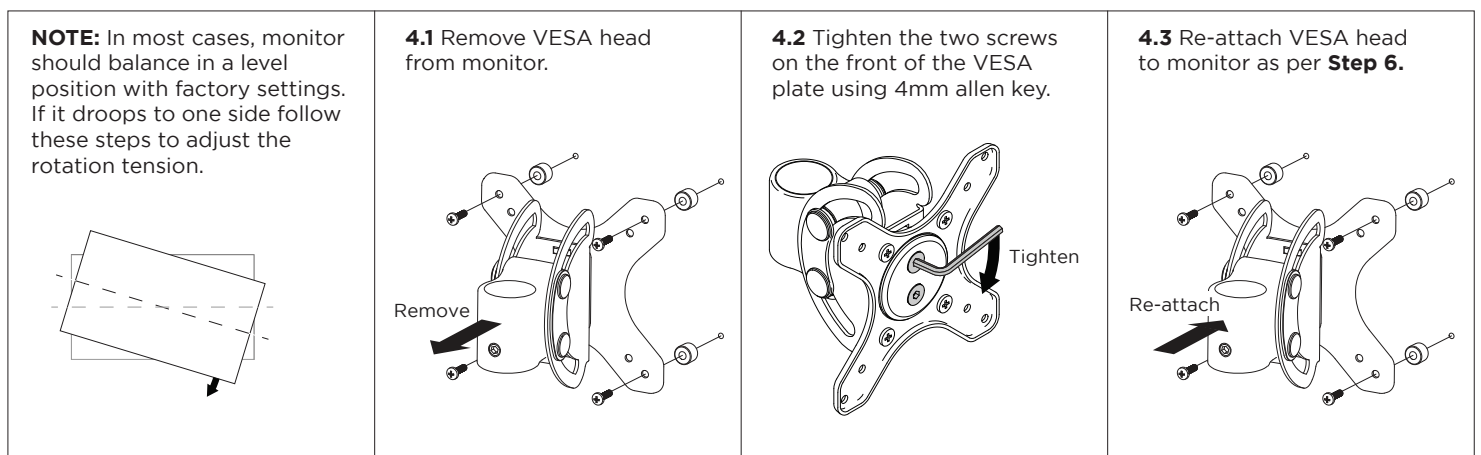

## 5. Lock monitor rotation (Optional)

**OPTIONAL** To lock monitor rotation screw the four M5x16 screws into the four holes on the front of the VESA Head.

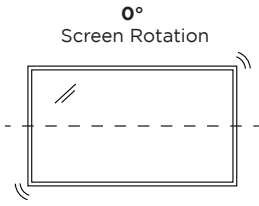

**5.1** Ensure VESA Plate is in this orientation before installing screws.

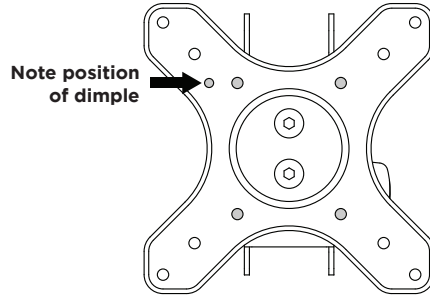

**5.2** Install the four Rotation Security Screws **G** into the front of the VESA Head

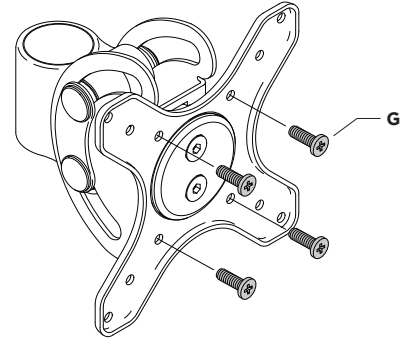

## 6. Attach VESA head to monitor

**6.1** Check VESA mounting compatibility

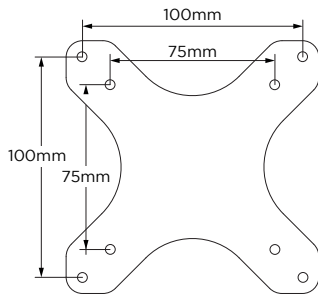

**Note:** For other sizes, use a suitable adaptor plate (sold separately).

**6.2** Attach VESA head onto monitor with provided screws.

**Note:** Spacers may be required for curved, recessed or uneven monitor surfaces.

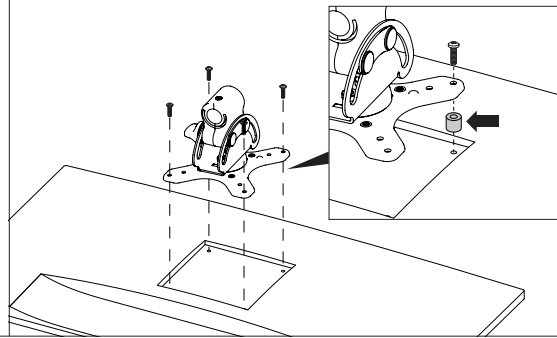

**Note:** be sure to use a screw length that suits the monitor.

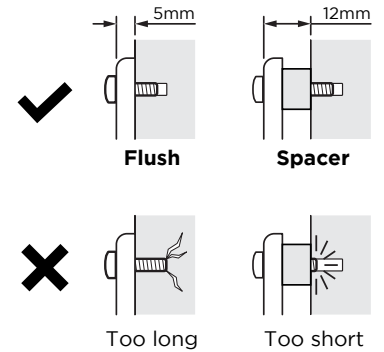

## 7. Mount monitor onto arm

**7.1** Push tilt head onto the shaft at the end of the monitor arm, grub screw must be backed off at this time.

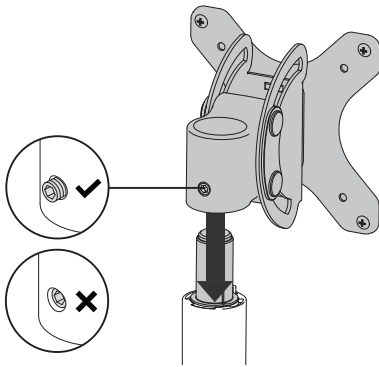

**NOTE:** Ensure plastic sleeve is on shaft before fitting tilt head.

**7.2** Ensure tilt head is fully pushed onto shaft.

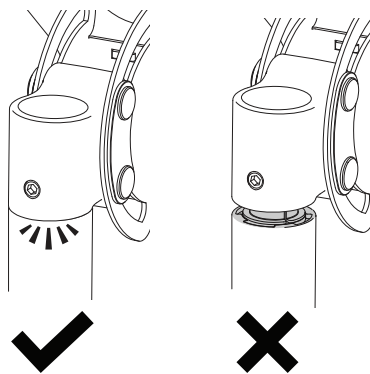

**7.3** Tighten the joint screw with 4mm allen key to secure the tilt head and monitor in place.

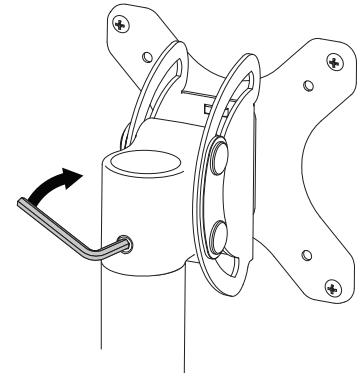

**NOTE:** Check the head pan adjustment is smooth after tightening.

## 8. Adjust tilt tension

**8.1** Use the knob to tighten and loosen the tilt tension to suit your monitor weight.

**NOTE:** Always support the monitor whilst adjusting to prevent it from falling forward sharply.

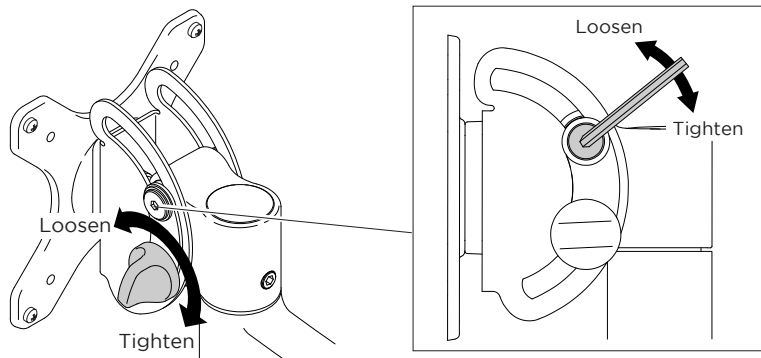

**IMPORTANT**  
If extra tilt tension is required for your monitor, use 4mm allen key to tighten second tilt screw.

## 9. Monitor arm cable management

**9.1** Plug cables into the monitor and route the cables down the arm using the cable hooks and clips

